

EK 90



MULTI-PURPOSE PILING RIG

EK90

The GEAX EK90 is a multi-purpose piling rig designed to achieve the highest levels of versatility, ease of use, manoeuvrability, transportation, production and reliability. It is configured to operate in various different piling modes including rotary kelly piling, CFA piling and diaphragm walling. As most of the components are modular, the conversion from one mode to another is extremely simple and fast.

The GEAX EK90's outstanding production capability is comparable to machines of a much larger size. Its excellent stability allows easy manoeuvrability on job sites and ensures fast and safe operating movements. Its compactness and low weight allows easy transportation without special permits.

The Hitachi Zaxis 160LC-3 or JCB JS160 NC base carrier, constructed to GEAX specifications, ensures excellent reliability and maintenance with operator cabin comfort not available on proprietary machines.



The GEAX EK90 (in common with other GEAX machines) has an articulation structure similar to a normal excavator with a long boom supporting the mast. This allows a wide range of mast positioning and independent adjustment of the vertical position of the mast. Wire rope positions are not dependent on the position of the mast as the winches are mounted on the mast itself. This design, compared to other machines, usually with parallelogram type mast supports, ensures the following:

- Excellent rigidity and lightness
- Fast setup time
- Simpler maintenance
- More precise movements
- Wide range of tool positioning
- Better visibility for the operator

Electronic devices

EK series machines are equipped with an electronic system which controls and displays several functions and parameters.

- Automatic alignment of the mast
- Mast inclination display
- Depth measuring device
- Pressure gauge for an auxiliary input

A GPS system enables GEAX owners to monitor and manage their machines remotely by a PC connected to the Internet

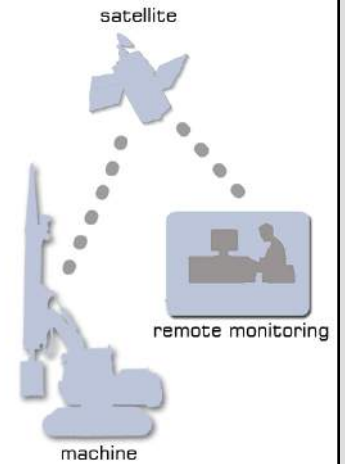
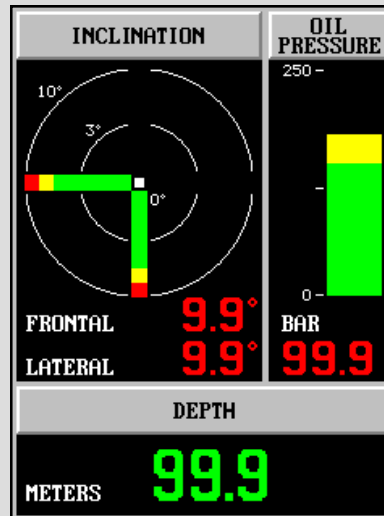

BPS patented crowd system for CFA piling

The pull-down system type BPS is GEAX's patented crowd system for CFA piling, providing a mechanical locking system between the rotary head and the mast which creates a crowd force on the auger and the crowd force is available along the entire length of the mast.

The pull-down system is activated only when needed by the operator and requires no pulleys or ropes.

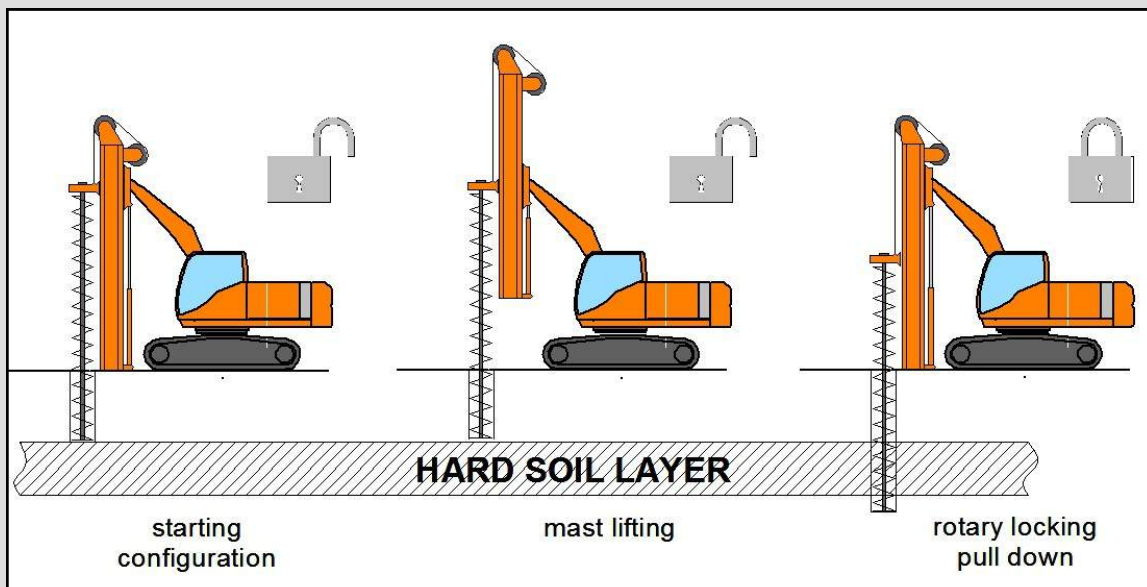
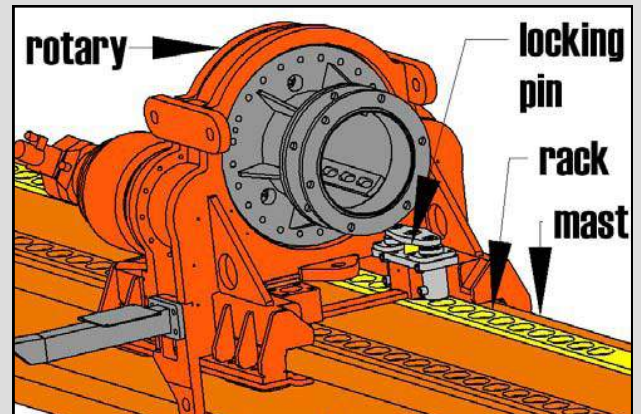

www.geax.it

info@geax.it

EK90 P

Kelly Piling

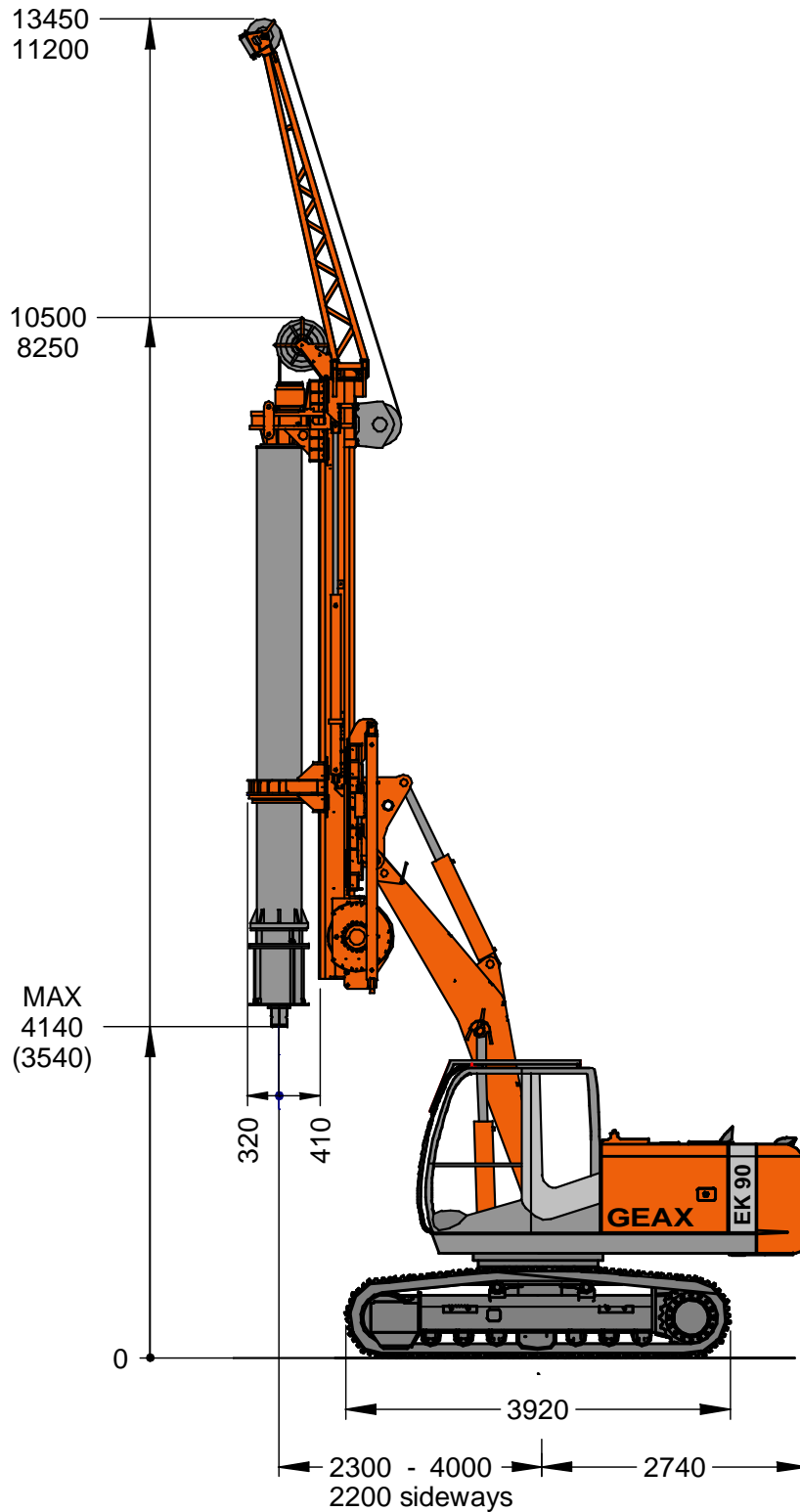

MULTI-PURPOSE PILING RIG

www.geax.it

info@geax.it

EK90 CFA

CFA Piling

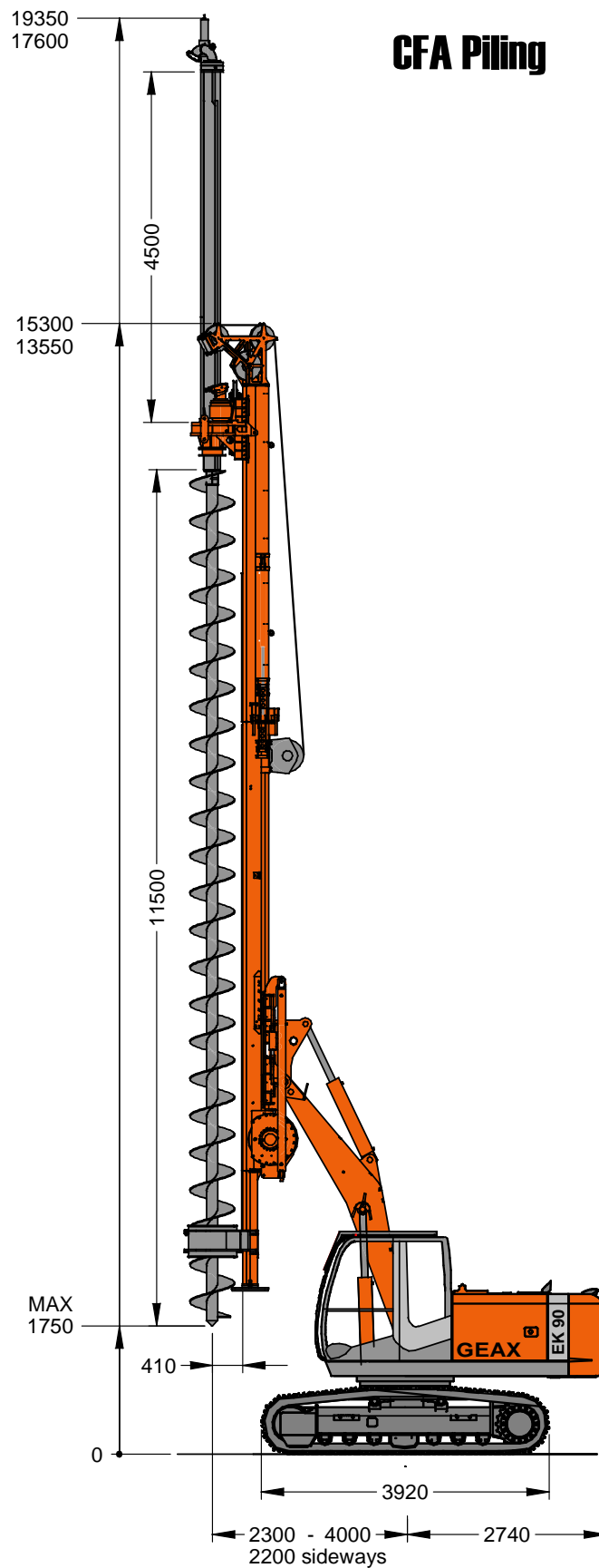

MULTI-PURPOSE PILING RIG

www.geax.it

info@geax.it

EK90 D

Diaphragm Walls

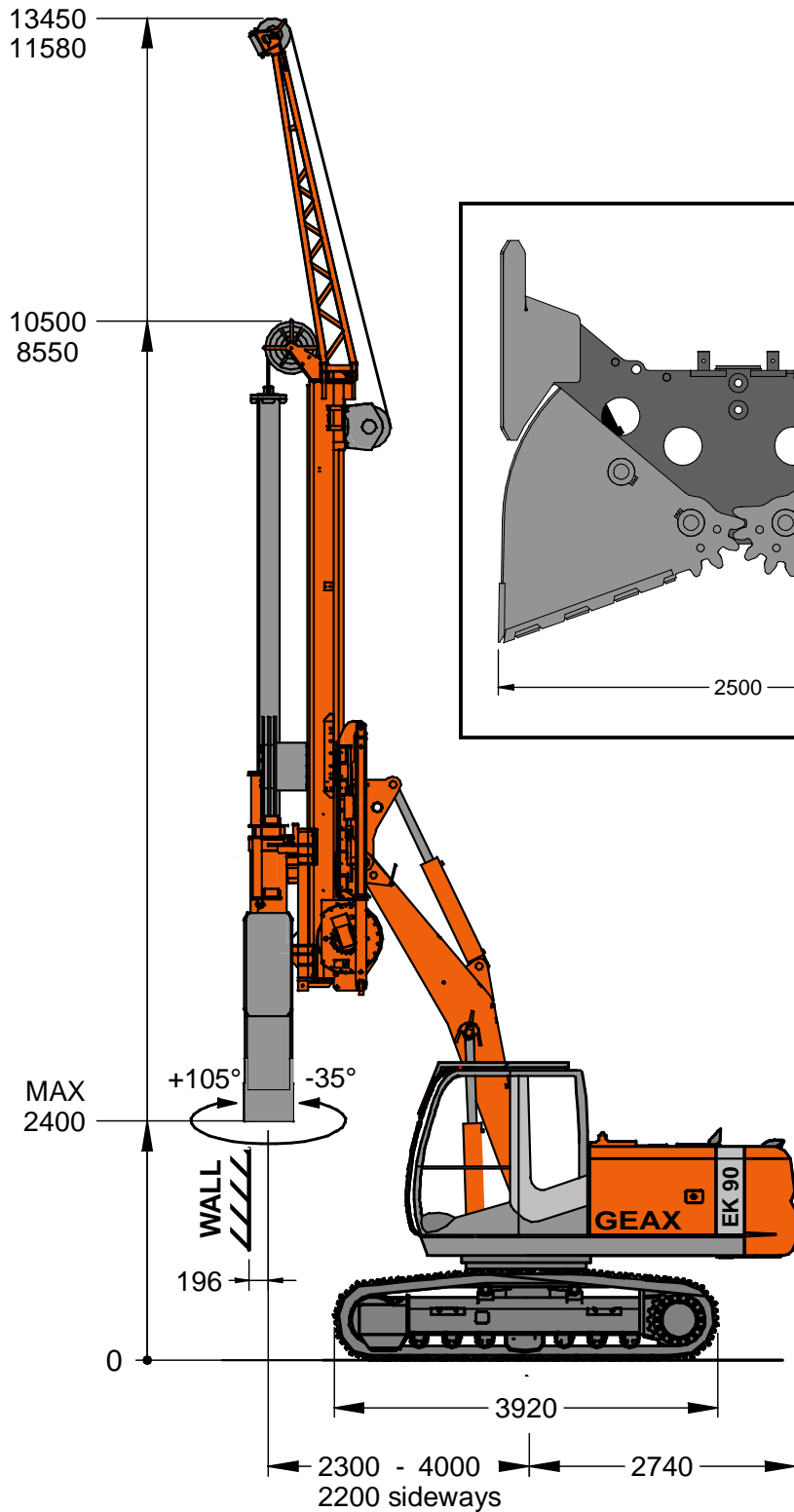

MULTI-PURPOSE PILING RIG

Technical features

Base HITACHI/JCB		Zaxis160LC-3 / JS160 NC		
Engine	type	ISUZU AI-4JJ1X / JCB Dieselmex 444		
Engine power	Kw(hp)	90.2(121)/97(130)		
Undercarriage length	mm - ft	3920 - 12.9		
Undercarriage width	mm - ft	2490 - 8.25		
Shoe width	mm - in	500 - 19.7		
Hydraulic system				
Main pumps	l/min	2x191 / 2x164		
Auxiliary pump	l/min	2x33.6 / 2x20.5		
Hydraulic pressure	bar	320		
Rotary		EK90 P	EK90 CFA	EK90 D
Nominal torque (overboost)	kNm - ft lbs	82 (90) - 60,500 (66,400)		-
Drilling speed (3)	rpm	6÷85		-
Rotary+mast stroke	mm - ft	3850 - 12.6	12750 - 41.8	2250 - 7.4
Winches				
Main winch line pull	kN - lbs	120 - 27,000	240 - 54,000	120 - 27,000
Main winch rope diameter	mm - in	22 - 0.86	20 - 0.78	22 - 0.86
Aux winch line pull	kN - lbs	37 - 8,300		
Aux winch rope diameter	mm - in	14 - 0.55		
Crowd system				
Pull down force	kN - lbs	100 - 22,500	100 - 22,500	-
Extraction force	kN - lbs	180 - 40,500		
Excavation				
Max pile diameter	mm - in	1500 - 60	750 - 30	-
Max pile/wall depth	m - ft	31 - 102	16.5 - 54	16 - 52.5
Width of trench	mm - in	-	-	300-11.8 ÷ 800-31.5
Length of trench	mm - in	-	-	2500 - 98.5
Grabs closing force	kN - lbs	-	-	200 - 45,000
Grab rotation	deg	-	-	+105°÷-35°
Transport				
Length (A)	mm - ft	10500 - 34.5	10200 - 33.5	10500 - 34.5
Width	mm - ft	2490 - 8.25		
Height	mm - ft	3050 - 10		
Weight	t - lbs	26 - 57,300	25 - 55,100	26 - 57,300

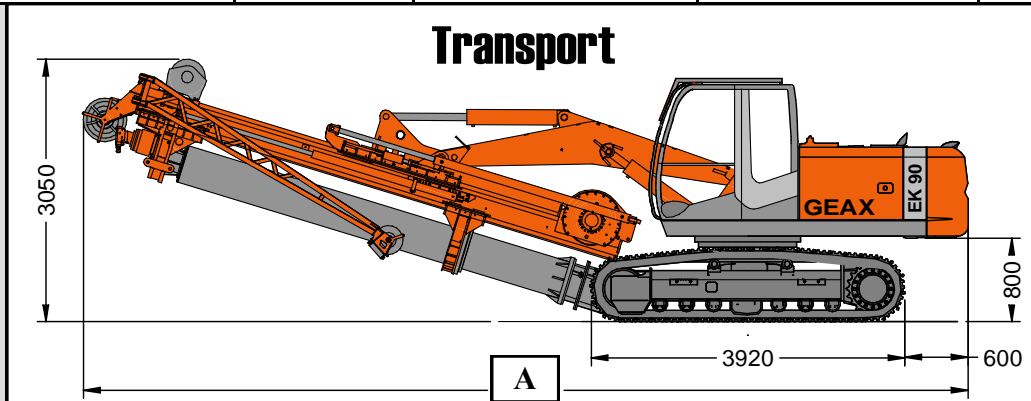



Technical specifications are subjected to change without prior notice

GEAX s.r.l.

Via Campoceraso 13 60027 Osimo (AN) Italy
tel. +390717131953 fax. +39071715199
info@geax.it www.geax.it

DEALER